

## Applications

- Node Capability
- Narrow Transmitter Housing
- Networks with Limited Fiber
- Architectures Using Separate Optical Wavelengths to Carry Targeted Services

## Features

- DOCSIS 3.1 compliant
- 1.2 GHz Bandwidth
- Standard ITU Grid Wavelengths
- Advanced Analog Chip Design
- Reduces Equipment Requirements in the Hub
- Telcordia Technologies<sup>®</sup> 468 Compliant
- Wide Temperature Range – Stable Even in Harsh Environments

The 1752A is a Dense Wavelength-Division Multiplexing (DWDM) laser module that is fully DOCSIS 3.1 compliant and can support operational bandwidth of up to 1.2 GHz. The 1752 laser platform has been designed specifically for CATV applications with a wide operating temperature range for reliable performance in harsh node environments and narrow linewidth transmitter designs. The 1752A DOCSIS 3.1 DWDM DFB laser module features low adiabatic chirp to maximize signal quality in short and long lengths of fiber. The laser's excellent inherent linearity minimizes degradation of the broadcast signals caused by Quadrature Amplitude Modulated (QAM) channels. The versatile 1752A laser module reduces cable network architecture fiber needs and lessens equipment requirements in the hub.

The 1752A is available in a wide range of ITU grid wavelengths with industrial temperature performance.

## Performance Highlights

Parameters	Min	Typical	Max	Units
Available Wavelengths (ITU Grid)	1526	-	1563	nm
Optical Output Power (multiple versions)	6-10	-	-	mW
Temperature Case Temperature Range	-40	-	+85	°C
Frequency Range:	40 MHz	-	1.2	GHz
Composite Second Order	-	-	-38	dBc
Composite Triple Beat	-	-	-60	dBc
Adiabatic Chirp (measured at 500 MHz)	40	-	100	MHz/mA

## Absolute Maximum Ratings

Stresses in excess of the absolute maximum ratings can cause permanent damage to the device. These are absolute stress ratings only. Functional operation of the device is not implied at these or any other conditions in excess of those given in the operational sections of the data sheet. Exposure to absolute maximum ratings for extended periods can adversely affect device reliability.

Parameter	Symbol	Condition	Min	Max	Units
Operating Case Temperature	$T_C$	continuous	-40	+85	°C
Storage Temperature	$T_{STG}$	-	-40	+85	°C
Laser Forward DC Current	-	-	-	150	mA
Reverse Voltage Photodiode	$V_{RPD}$	-	-	10	V
Laser Reverse Voltage, DC	$V_R$	-	-	1	V
ESD	-	HBM: R = 1500 Ohm, C = 100 pF	-500	500	V
TEC Current	$I_{TEC}$	continuous	-1.7	1.7	A
RF Input Power	$P_{RFIN}$	$I_F = I_{OP}$	-	62	dBmV

## Electrical/Optical Characteristics

Laser Temperature ( $T_L$ ) = 25°C,  $I_F = I_{OP}$ , Beginning of Life (BOL)

Parameter	Symbol	Condition	Min	Typ	Max	Unit
Wavelength <sup>1</sup>	$\lambda_{OP}$	$I_F = I_{OP}$ , $T = T_{OP}$	1525	-	1564	nm
Optical Output Power	$P_O$	1752xxxx-10 version	10	-	-	mW
Slope Efficiency	SE	Points measure @ $I_F = I_{TH} + 20$ mA & $I_F = I_{TH} + 60$ mA	0.16	0.19	-	mW/mA
Optical Isolation	ISO		30	-	-	dB
Sidemode Suppression Ratio	SMSR		35	-	-	dB
Laser Relative Intensity Noise	RIN	$I_F = I_{TH} + 70$ mA,  $T = 25$ °C	-	<-155	-	dB/Hz
Wavelength Drift as Case Temp. is Changed	$\lambda_{\Delta}$	$I_F = 60$ mA, $T = T_{OP}$ , $T_C$ varied from min→max	-	-	0.04	nm
Threshold Current	$I_{TH}$		-	-	20	mA
Operating Current	$I_{OP}$		-	-	120	mA
Monitor PD Responsivity	$r_{PD}$	$V_{RM}=5$ V	10	-	200	μA/mW
Thermistor Resistance	$R_{TH}$	$T_{OP}=25$ °C	9.5	10	10.5	KΩ
Thermistor Temperature Coefficient	$TC_{TH}$	$T_{OP}=25$ °C	-	-4.4	-	%/°C
TEC Current	$I_{TEC}$	-40< $T_C$ <+85°C $I_F = 100$ mA	-1.5	-	1.6	A
Fiber Length	-	May include splice	1.0	1.5	-	m
Fiber Buffer	-	-	-	900	-	μm
Fiber Core / Cladding	-	-	-	SMF-28	-	μm

Measured Wavelength = Operating wavelength with a tolerance of ± 0.05 nm.

## RF Characteristic

Parameter	Symbol	Condition	Min	Typ	Max	Units
Frequency Range <sup>1</sup>	F	$I_F = 60 \text{ mA}$	40	-	1200	MHz
Frequency Response Flatness <sup>1</sup>	S21	$I_F = 60 \text{ mA}$ , $T_{OP} = 25 \text{ }^\circ\text{C}$	-	$\pm 1$	$\pm 2$	dB
RF Return Loss <sup>1</sup>	S11	-	16	-	-	dB
Composite Second Order	CSO	$I_F = I_{OP}$ Note 2, 3	-	-	-38	dBc
Composite Triple Beat	CTB	$I_F = I_{OP}$ Note 2, 3	-	-	-60	dBc
Carrier to Noise Ratio	CNR	$I_F = I_{OP}$ Note 2, 3	51	-	-	dB
Adiabatic Chirp	FM	$I_F = 60 \text{ mA}$ , $T = 25 \text{ }^\circ\text{C}$ , measured at 500 MHz	40	-	100	MHz/mA
Nominal Input Impedance	$Z_{IN}$	-	-	25	-	dB

1. Measured on a 50Ω resistively matched system.
2.  $I_{OP}$  is the bias point at which simultaneously the linearity, the min. optical power and the required operating wavelength,  $\lambda_{OP}$  are obtained.
3. Test Conditions:

Fiber Launch Power:  $10.0 \pm 0.1 \text{ dBm}$ .  
 Peak OMI: 3.9% per channel ( $\pm 0.5 \text{ dB}$ )  
 Channel Load: 79 CW carriers from 55.25 MHz to 547.25 MHz  
 Measurement Frequencies:  
 CSO: 547.25 MHz; CTB: 295.25 MHz; CNR: 547.25 MHz  
 Fiber Length: 25 km SMF-28 fiber  
 Receiver Input Power:  $0.0 \pm 0.1 \text{ dBm}$   
 Receiver responsivity: 0.86 mA/mW Min.  
 Optical Reflection: -40 dBc Max. (excluding reflection from long-haul fiber)

## Electrical Schematics

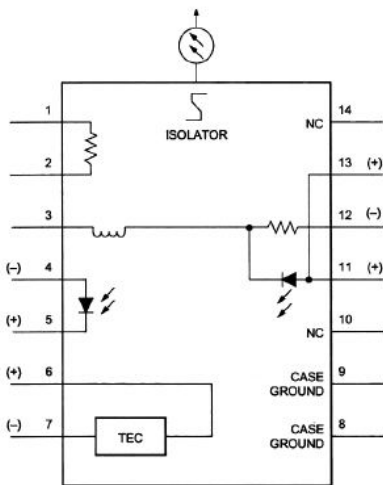

Figure 1. 1752A Laser Schematic

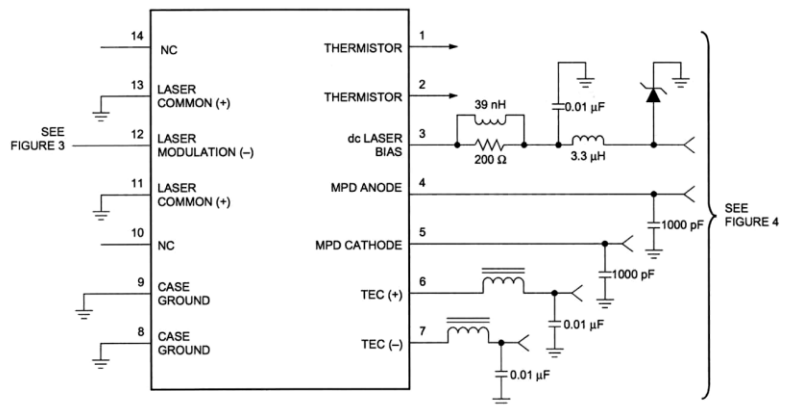
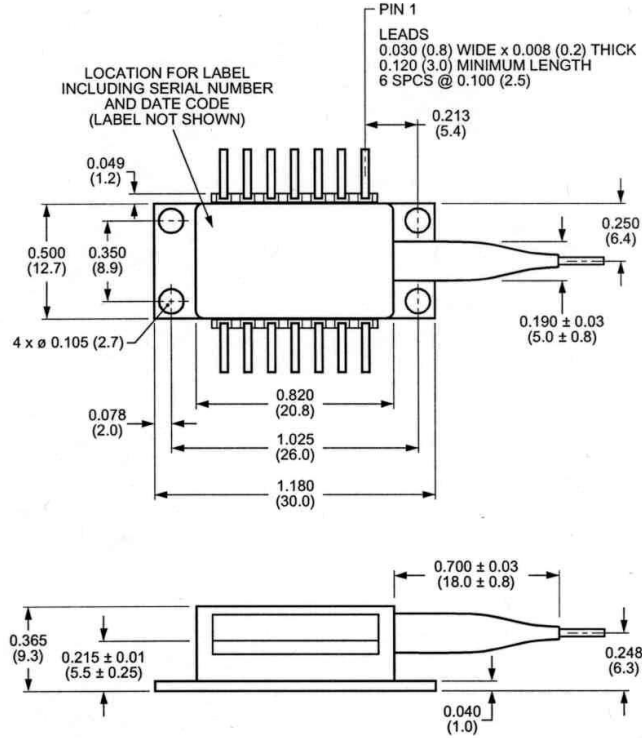

Figure 2. 1752A Suggested Interface Circuit

**Outline Diagrams (Dimensions are in inches and mm)**



**Pin Definitions**

Pin	Description
1	Thermistor
2	Thermistor
3	DC Laser Bias (-)
4	MPD Anode (-)
5	MPD Cathode (+)
6	Thermal Electric Cooler (+)
7	Thermal Electric Cooler (-)
8	Case Ground
9	Case Ground
10	NC
11	Laser Common (+), Case GND
12	Laser Modulation (-)
13	Laser Common (+), Case GND
14	NC

## Ordering Code Definitions

### 1752A-19-BB-SC-10

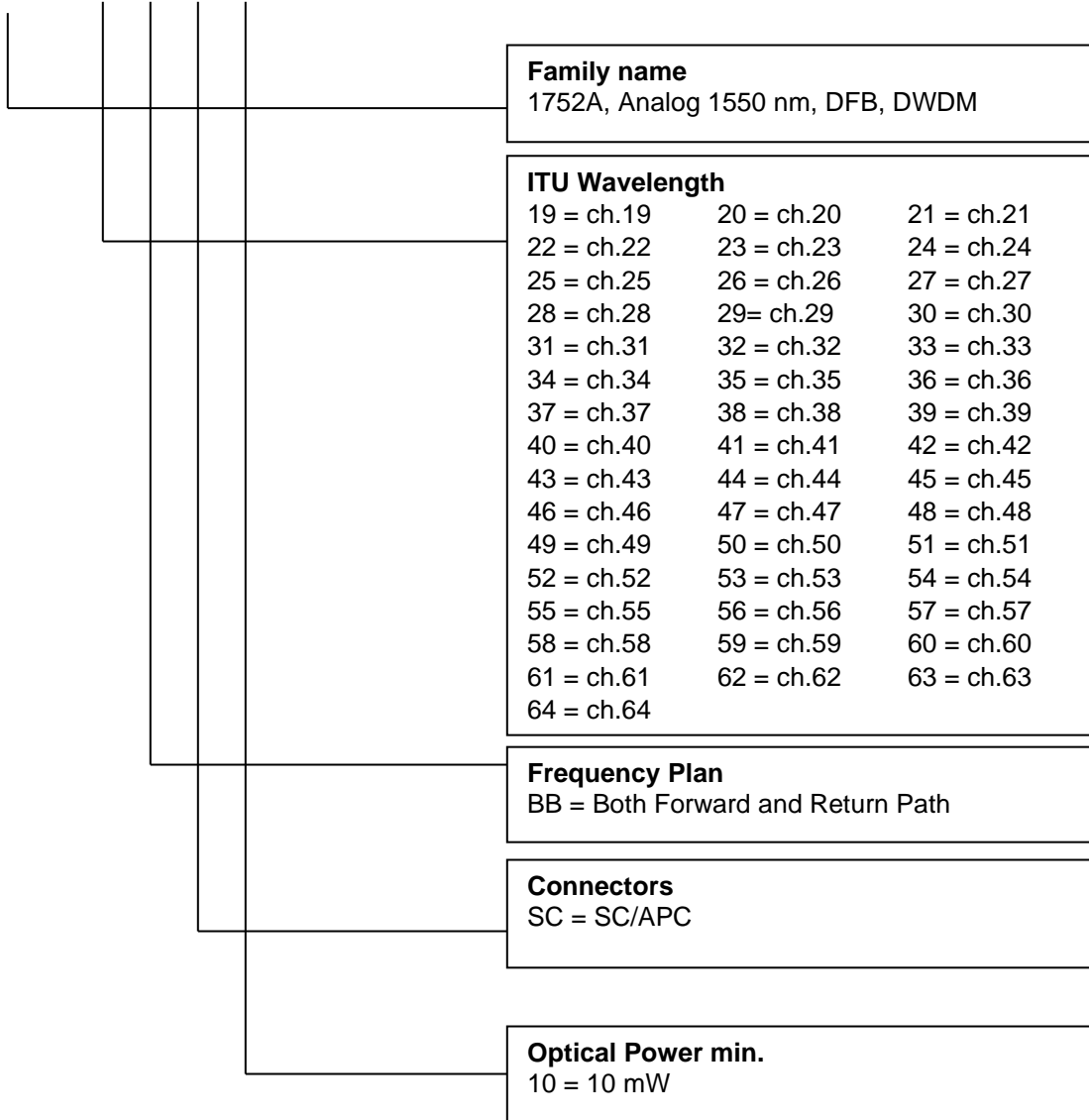

## Laser Safety

This product meets the appropriate standard in Title 21 of the Code of Federal Regulations (CFR). FDA/CDRH Class 1M laser product. This device has been classified with the FDA/CDRH under accession number 0220191.

All Versions of this laser are Class 1M laser product, tested according to IEC 60825-1:2014/EN 60825-1:2007 Single-mode fiber pigtail with SC/APC connectors (standard).

Wavelength = 1.5  $\mu$ m.

Maximum power = 30 mW.

Because of size constraints, laser safety labeling (including an FDA class 1M label) is not affixed to the module, but attached to the outside of the shipping carton.

Product is not shipped with power supply.

**Caution: Use of controls, adjustments and procedures other than those specified herein may result in hazardous laser radiation exposure. Viewing the laser output with telescopic optical instruments (for example, telescopes and binoculars) may pose an eye hazard and thus the user should not direct the beam into an area where such instruments are likely to be used.**

