



Applications

- Video Signal Distribution in RFoG and FTTx nodes
- Video Overlay in Passive Optical Networks (PON)

Features

- 5 MHz-200 MHz Bandwidth Supports the Return Path Application.
- Excellent RF Frequency, High RF Output.
- Low Noise (<1.0 pA/√Hz typ.) Low Power Dissipation (0.5 W max).
- RoHS Compliant
- Internal Proprietary Impedance Match Circuitry (75Ω)
- Robust Small Package with Single-Mode Fiber Pigtail and Connector Options
- Wide Operating Case Temp Range, -40° to +85°C

The 7820R RFoG return path optical receiver is a single-mode fiber pigtailed module featuring a low-noise, impedance-matched broadband photodiode and RF amplification.

The device receives optical analog and/or digital signals for a range of return path, and delivers the corresponding RF electrical output.

The 7820R exhibits excellent noise performance with values well above standards over the entire 200MHz bandwidth and case temperature specifications (-40°C to +85°C).

Moreover, the proprietary impedance-match circuitry between the photodetector and RF amplification stages resolves a number of OEM design obstacles. The device's noise performance is typically less than 0.75pA/√Hz for the 85MHz version and 1pA/√Hz for the 200MHz version.

The 7820R RFoG return path optical receiver can be used in the optical wavelength range from 1260nm – 1620nm applications.

The 7820R is compliant with all criteria of the Restriction of the Use of Hazardous Substances in Electrical and Electronic Equipment (RoHS) guidelines 2002/95/EC.

Performance Highlights

Parameter	Limits
Frequency Range	5 – 200 MHz
Noise	
5 – 85MHz Version	0.75 pA/√Hz (typ)
5 – 200MHz Version	1.0 pA/√Hz (typ)
DSO (20% OMI/tone)	-60 dBc (typ)
DTO (20% OMI/tone)	-50 dBc (typ)
Optical Input Power	Up to -10dBm
Wavelength	1260 – 1620 nm
Power Consumption	0.5 W

Absolute Maximum Ratings

Stresses in excess of the absolute maximum ratings can cause permanent damage to the device. These are absolute stress ratings only. Functional operation of the device is not implied at these or any other conditions in excess of those given in the operational sections of the data sheet. Exposure to absolute maximum ratings for extended periods can adversely affect device reliability.

Parameter	Symbol	Min	Max	Unit
Operating Case Temperature Range	T_{CASE}	-40	85	°C
Storage Temperature Range	T_{stg}	-40	85	°C
Humidity at 85 °C	RH	--	85	%

Note: For all tables, typical values are performed at 25°C; min and max values are performance vs. temperature.

Electrical/Optical Characteristics

Parameter	Symbol	Min	Typ	Max	Unit
Optical Power 5 – 85MHz Version 5 – 200MHz Version	P_{IN}	--	--	-10 -7	dBm
Optical Return Loss	RL_{OPT}	40	--	--	dB
DC Power +5V Amp Bias, (Pin 2) +12V PD Bias, (Pin 6)	I_{CCA} I_{CCP}	-- --	-- --	100 1	mA mA
Wavelength	λ	1260	1310/1550	1620	nm
Responsivity	--	-- --	>0.8 at 1310 nm >0.9 at 1550 nm	-- --	mA/mW mA/mW
PDI Monitor Voltage	V_{MON}	--	10	--	V/mA
Dissipation	P_{DISS}	--	--	0.5	W

RF Characteristics

Parameter	Symbol	Min	Typ	Max	Unit
Frequency Response	BW	5	--	85	MHz
Gain (Ref @ 5MHz) 5 – 85MHz Version 5 – 200MHz Version	G	36 29	--	38 31	dB
Gain Stability (-40°C to +85°C)	G_{ST}	-0.5	--	+0.5	dB
Ripple	--	--	1	1.2	dBpk-pk
Gain Tilt ⁽³⁾	--	--	1	2	dB
RF Output Level ⁽²⁾ 5-85 MHz Version 5 – 200 MHz Version	RF_{OUT}	37 35	--	39 37	dBmV/ch

RF Characteristics (continued)

Parameter	Symbol	Min	Typ	Max	Unit
Output Return Loss	RL	--	--	-16	dB
Equivalent Input Noise	EIN	--	0.75	0.9	pA/√Hz
5 – 85MHz Version			1.0	1.30	
Discrete Second-Order ^(1,2)	DSO	--	-60	-50	dBc
Discrete Third Order ^(1,2)	DTO	--	-70	-60	dBc

- (1). Two laser test at 1310 nm/1550 nm. 40% OMI/tone (before combined). Distortion products measured at 40 and 85 MHz.
- (2). 5 – 85MHz Version, Optical Input = -10dBm, OMI = 20% (after combined)
5 – 200MHz Version, Optical Input = -7dBm, OMI = 20% (after combined)
- (3). Tilt is defined as the delta between 5 – 85MHz for 7820R-085 and 5 – 200MHz for 7820R-200.

Outline Drawing (dimensions are in inches & mm)

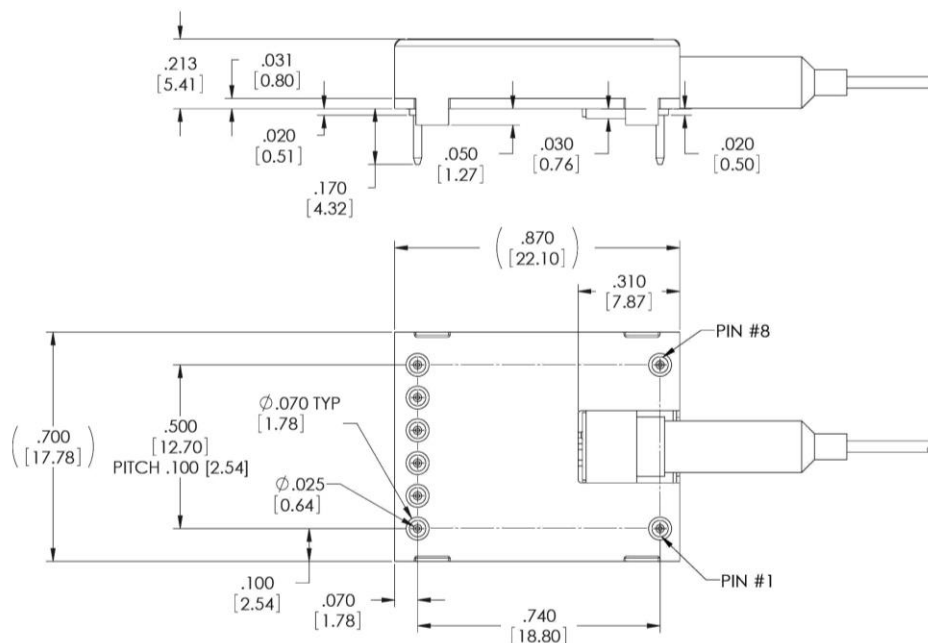
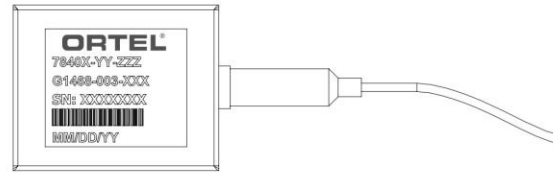

7820R Optical Receiver

5-200 MHz RFoG Return Path

DATASHEET | JANUARY 2024

CATV-RFOG

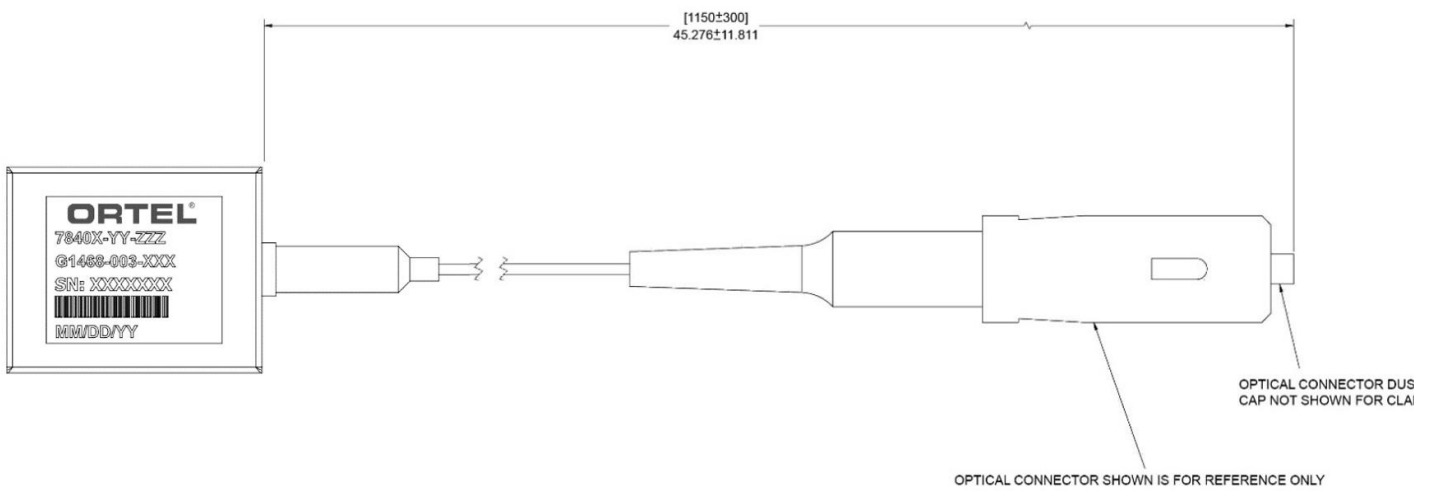
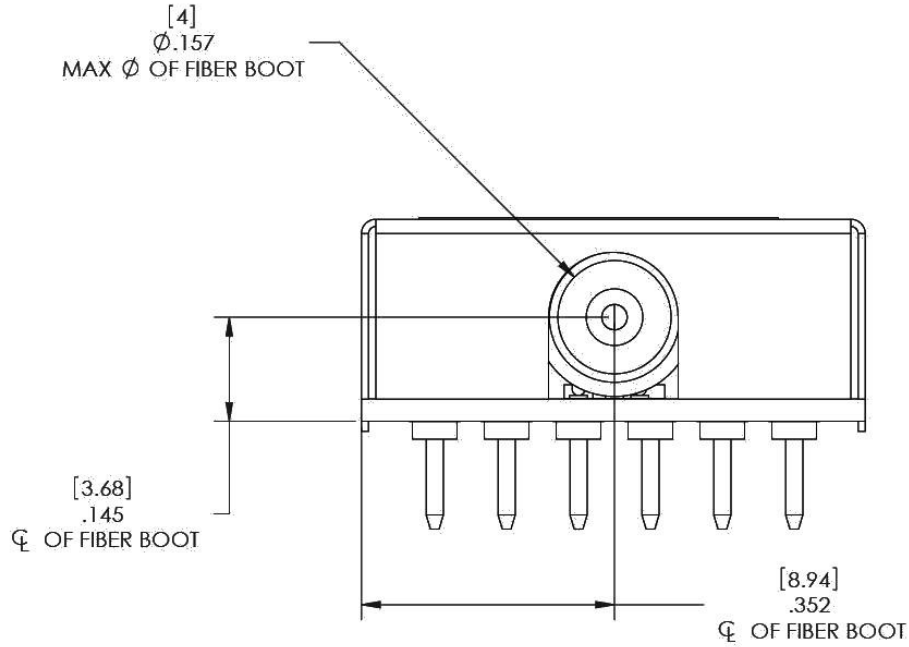

7820R Optical Receiver

5-200 MHz RFoG Return Path

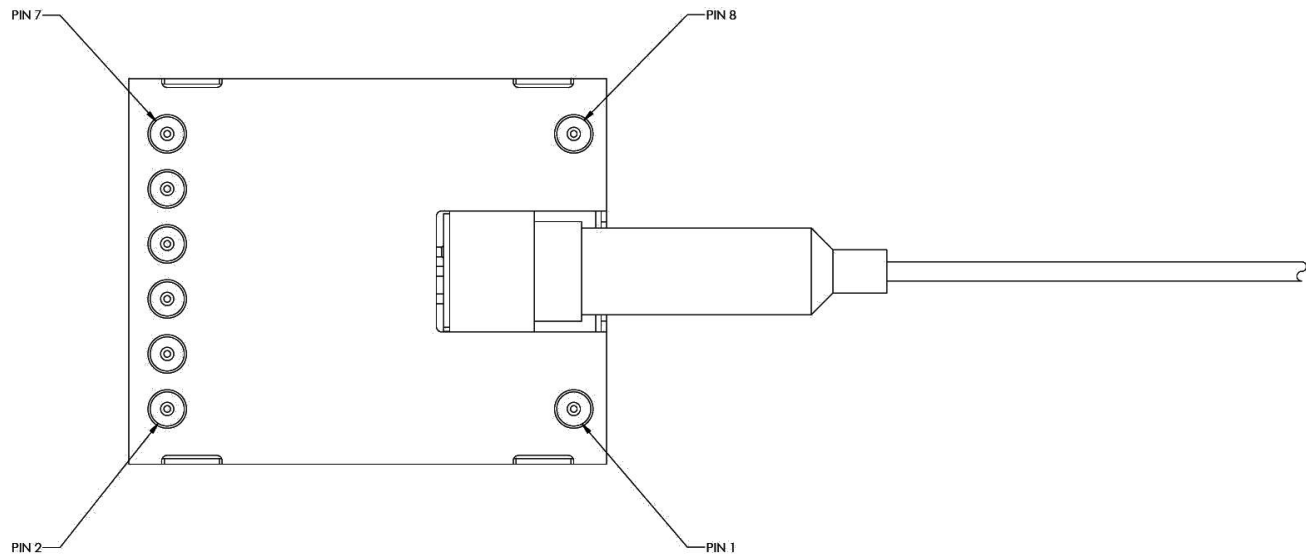

Pin Definitions

Pin	Function
1	GND
2	+5V
3	GND
4	RF OUT
5	GND
6	+12V
7	PD MONITOR
8	GND

Ordering Code Definitions

7820R-xxx-yy-zzz

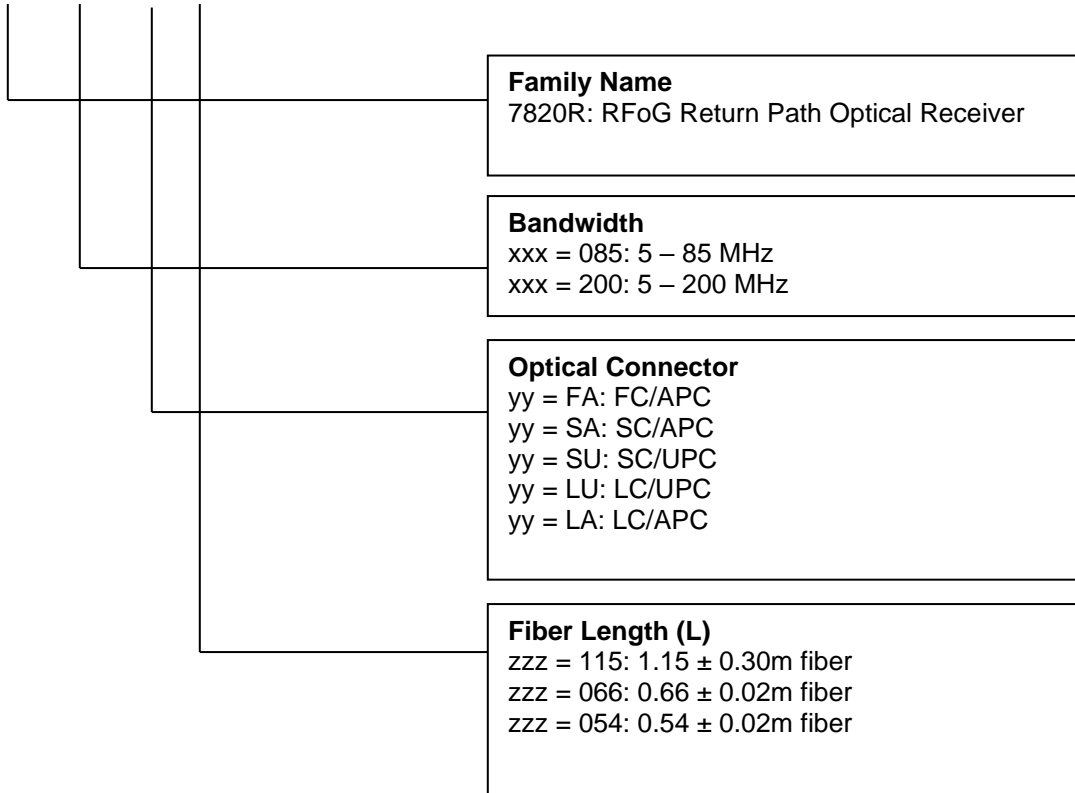

Example:

7820R-085-SA-115: RFoG Return Path Receiver, 5-85 MHz, SC/APC Connector, 1.15m Fiber