



Applications

- Fiber Optic Delay Lines
- Long Distance RF/Microwave Fiber Optics Communication Links
- Sensing and Control Systems
- CATV Systems
- High-Performance Supertrunking Links
- Redundant Ring Architectures
- FTTx Networks

Features

- Full Function Fiber Optic Pre-amplifier Ready for Integration
- Wavelength Range: 1530nm to 1562nm
- Low Noise Figure (Typ < 3.5 dB)
- Pin: ≤ -4.0 dBm
- Pout: saturated = 14 dBm, 17 dBm
- Small Signal Gain ≥ 37 dB
- RS-232 Monitor and Control Interface
- Low Electrical Power Consumption
- Output Isolation > 35 dB
- Polarization Dependent Gain (PDG) < 0.5 dB
- Polarization Mode Dispersion (PMD) < 0.5 ps
- Output Return Losses < -40 dB
- Polarization Dependent Loss < 0.3 dB

The Ortel MAFA 5000 Series Micro Erbium Doped Fiber Pre-amplifier gain block module is an ideal building block for OEM systems integration where there is a requirement to pre-amplify a 1550 nm signal for a broad range of applications including RF/microwave fiber optic links, fiber optic delay lines, sensing and control systems, and more. The family of MAFA 5000 EDFA gain blocks is designed to meet the most demanding noise performance requirements of fiber optic links and perform all the functions required of an optical pre-amplifier for system integration.

In order to achieve extremely low Noise Figures (NF), a pre-amplifier's input losses must be minimized. The MAFA 5000 Series Micro Erbium Doped Fiber Pre-amplifier design removes input isolation and input monitoring normally found on traditional booster amplifier designs to this end.

MAFA 5000 Series Micro Erbium Doped Fiber Pre-amplifier gain blocks provide output optical isolation for stable operation. The output optical signals are detected for monitoring and control. The pump laser bias current is controlled with constant current.

The MAFA 5000 has built-in monitors for all critical operating parameters, and generates alarms when parameters exceed established thresholds. The optical output of the MAFA 5000 Series Micro Erbium Doped Fiber Pre-amplifier gain blocks can be split into multiple ports (2, 3 or 4) by an optional internal splitter.

The compact mechanical footprint of the MAFA 5000 allows use of this unit in constrained space environments and high density applications.

Optical/Electrical Characteristics Note 1

Property	Unit	Limit	Models		Comments
			14	17	
Operating Input Power	Pin (dBm) Min/Max	Typ	-45/-4	-45/-4	Recommended
Total Output Saturated Power	Po (dBm)	Nominal	14 +/- .25	17 +/- .25	Before Splitter (if installed) Note 2, 3
Flatness	ΔG (dB)	Typ	\leq +/-3.0 dB	\leq +/-3.0 dB	Note 4
Noise Figure	NF (dB)	Typ	\leq 3.5 dB	\leq 3.5 dB	Note 5
Output Power Stability	(dB)	Max	+/- 0.3	+/- 0.3	Note 6
Power Consumption (Steady state)	Psys(W)	Max	3	5.5	Note 7

Notes:

- 1) Unless stated otherwise, all specifications apply over the full operating temperature and humidity ranges
- 2) Measurement variations
- 3) Measured @ 25°C, Pin \approx -4.0 dBm. $\lambda \approx$ 1555 nm
- 4) Measured @ 25°C, Pin_{total} \approx -20.0 dBm, $\Delta\lambda \approx$ from 1530 nm to 1562 nm
- 5) Measured @ 25°C, Pin \approx -30 dBm. $\lambda \approx$ 1555 nm
- 6) Over polarization and temperature
- 7) Max - power consumption @ -20°C or +70°C of case temperatures

General and Mechanical Specifications

Property	Requirement	Comments
Operating Wavelength	1530nm ~ 1562nm	Standard
Operating Case Temperature	0°C to 65°C	Standard*
Storage Temperature	-40°C to 85°C	Standard
Operating Humidity	up to 95%	Non-condensing
Voltage Supply Range	+5 VDC	All versions
Optical Connectors	SC, FC, E2000, LC	User Specified
Dimensions (mm)	70 x 90 x 15	All versions

* - Extended case temperature range of -20°C to +70°C is also possible

Outline Drawing (dimensions in mm)

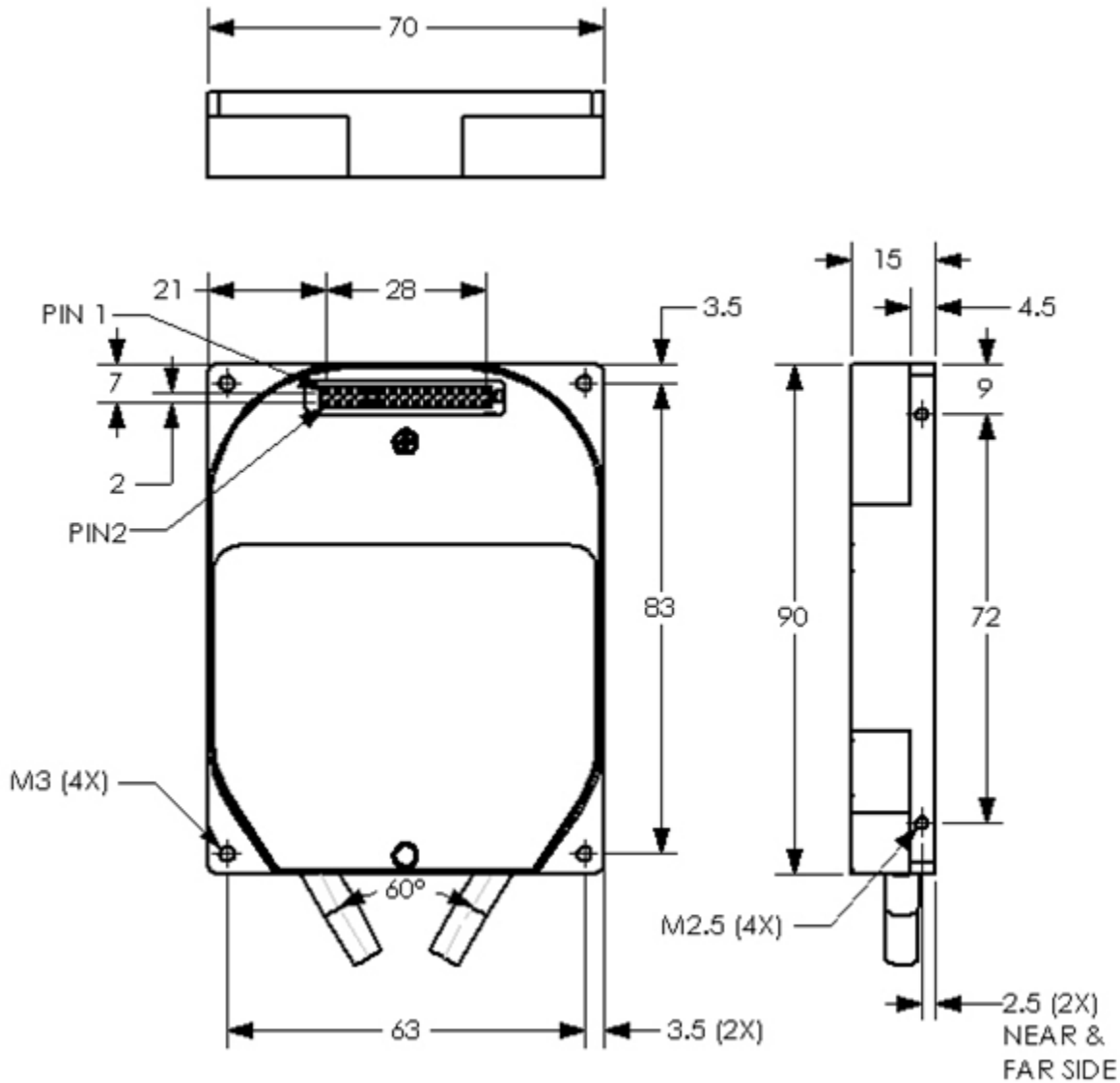

Compliance and Reliability Information

Class 3B Laser Safety

221,000 hours MTBF at 50°C per Telcordia SR-332, Issue 2

Electrical Connector Pinout

PIN #	Designation	PIN #	Designation
1	5VDC	16	NC
2	+5VDC	17	Pump_Temp_Alarm (TTL/LVTTL active high)
3	+5VDC	18	Pump_Bias_Alarm (TTL/LVTTL active high)
4	+5VDC	19	Loss_Input_Power (TTL/LVTTL active high)**
5	GND	20	Loss_Output_Power (TTL/LVTTL active high)
6	GND	21	GND
7	RxD (TTL/LVTTL)	22	GND
8	TxD (TTL/LVTTL)	23	Input Power Mon
9	GND	24	Output Power Mon
10	GND	25	GND
11	NC	26	GND
12	EDFA_Reset (TTL/LVTTL active high)	27	RxD
13	EDFA_Disable (TTL/LVTTL active high)	28	TxD
14	Pout_Mute (TTL/TTL/LVTTL active high)	29	+5VDC
15	EDFA_Temp_Alarm (TTL/LVTTL active	30	+5VDC

* - SAMTEC, TMM-115-01-L-D

** - Not applicable for MAFA 5000 pre-amplifiers

Ordering Information

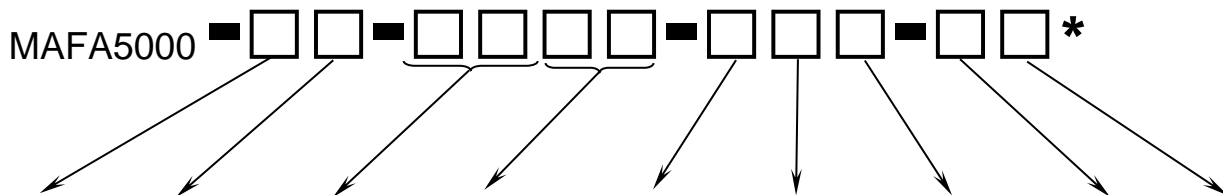

Logo & Customer Specifics	Temperature Option	Saturated Output Power dBm	Number of Output Ports	Input Connector Type	Output Connectors Type	Required Power Supply	Model	Future Use
0 = Emcore Logo	S = Standard	14 = 14	01 = 1 port	1 = SC/APC	1 = SC / APC	1 = +5VDC	P = Preamp	0 = NA
				2 = FC/APC	2 = FC / APC			
	E = Extended	17 = 17	02 = 2 ports	3 = E2000 / APC	3 = E2000 / APC			
				4 = LC / APC	4 = LC / APC			
			03 = 3 ports					

Example:

MAFA5000-0S-1401-111-P0: MAFA5000 gain block, with EMCORE logo, standard temperature range, 14 dBm saturated output power, 1 output port, SC/APC connector on input, SC/APC connector on output, +5VDC power supply required, preamplifier

Laser Safety Information

This component product classified as a Class 3B laser product based on the maximum optical output power defined below.

Wavelength = 1530 nm ~ 1562 nm (dependant on input source)

Maximum Output Power < 0.05 W (single output, 17.0 dBm model)

