

Applications

- Radar Testing/Calibration
- Signal Processing
- Phased Array Antennas
- Phase Noise Processing

Features

- Delays Up to 280 Microseconds
- Various Form Factors
- Small Size
- Flat RF Amplitude Response and Phase

The 35XX Series Fiber Optic Delay Lines deliver unmatched performance for radar testing, signal processing, phased array antennas and phase noise testing. When used in conjunction with either the 5016A/B/C/D fiber optic transceiver, System 10000 rack-mount transmitters and receivers, or Ortel flange-mount transmitters and receivers, these rugged devices eliminate many of the problems that are inherent in alternative delay line technologies including acoustic wave devices and coaxial delay lines.

Ortel's fiber optic delay lines provides bandwidth and insertion loss that are essentially independent of delay and triple transit signals that are immeasurable. In addition to enhancing electrical performance, the delay lines provide several mechanical advantages. Ortel's technology takes advantage of the rigid, yet flexible properties of fiber optic cable to provide repeatable enhanced phase and group delay characteristics.

Ortel's 35XX Series Fiber Optic Delay Lines consist of three unique versions:

- 355A - Flange-Mount
- 356A/B - Double-Wide Plug-In, compatible with the System 10000 chassis
- 357A/B/C/D/E - Rack-Mount, which is integrated into the System 10000 chassis

The small size of these components allows for long delays in a compact package with the superior temperature stability of fiber.

Absolute Maximum Ratings

Stresses in excess of the absolute maximum ratings can cause permanent damage to the device. These are absolute stress ratings only. Functional operation of the device is not implied at these or any other conditions in excess of those given in the operational sections of the data sheet. Exposure to absolute maximum ratings for extended periods can adversely affect device reliability.

Parameter	Symbol	Condition	Min	Max	Units
Storage Temperature	T_{STG}	Continuous	-40	+85	$^{\circ}$ C

Optical Specifications

Parameter	Requirements	Units
Fiber	Single Mode SMF 28 (9/125)	μ m
Optical Connector	FC/APC	-
Time Delay ¹	0.1 to 280	μ s
Delay Time Accuracy	\pm 1.0	%
Insertion Loss ²	$2 + (\text{Delay Time}_{(\mu\text{-sec})} / 6.12_{(\text{dB}(\mu\text{-sec}))})$	dB(RF) max
Insertion Loss ³	$2 + (\text{Delay Time}_{(\mu\text{-sec})} / 12.24_{(\text{dB}(\mu\text{-sec}))})$	dB(Opt) max
Relative Delay vs. Temperature	6.5	ppm/ $^{\circ}$ C

Note 1: 4.89 microseconds = 1 km of fiber, 4.89 nanoseconds = 1 m of fiber

Note 2: Contribution of optical fiber to the RF insertion loss of overall system.

Note 3: Optical insertion loss based upon fiber distance.

Connector Options

Description	Specifications		
	355A	356A/B	357A/B/C/D/E
Optical Connector			
-020 FC/APC Bulkhead	X	X	X
-022 1 Meter FC/APC Pigtail	X	X	X

35XX Series, 280 μ s Max Fiber Optics Delay Lines

DATASHEET | JANUARY 2024

FIBER OPTICS

355A Outline Drawing

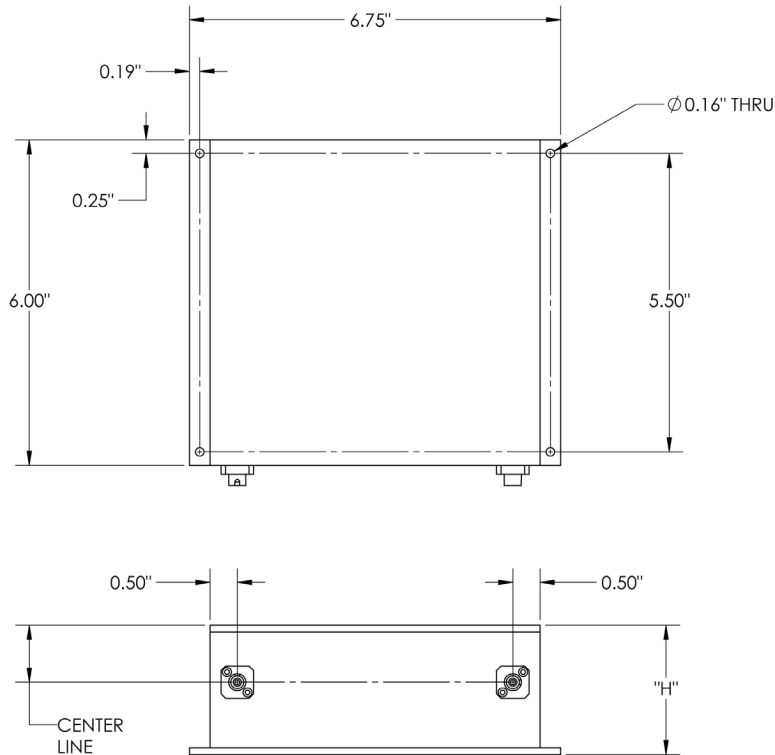

Delay (μ -sec)	Dimension "H"
0.5-35	2.38" / 60.5 mm
35.1-55	3.90" / 99.1 mm
55.1-75	4.75" / 120 mm
75.1-115	6.25" / 158 mm

356A/B Outline Drawing

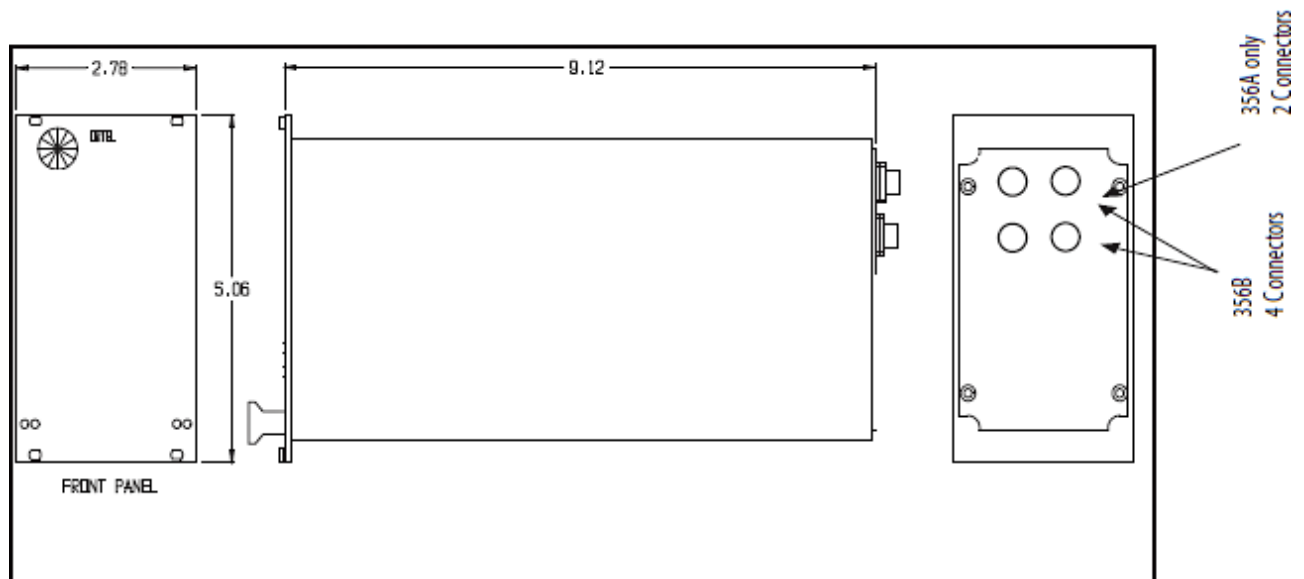

357A Outline Drawing

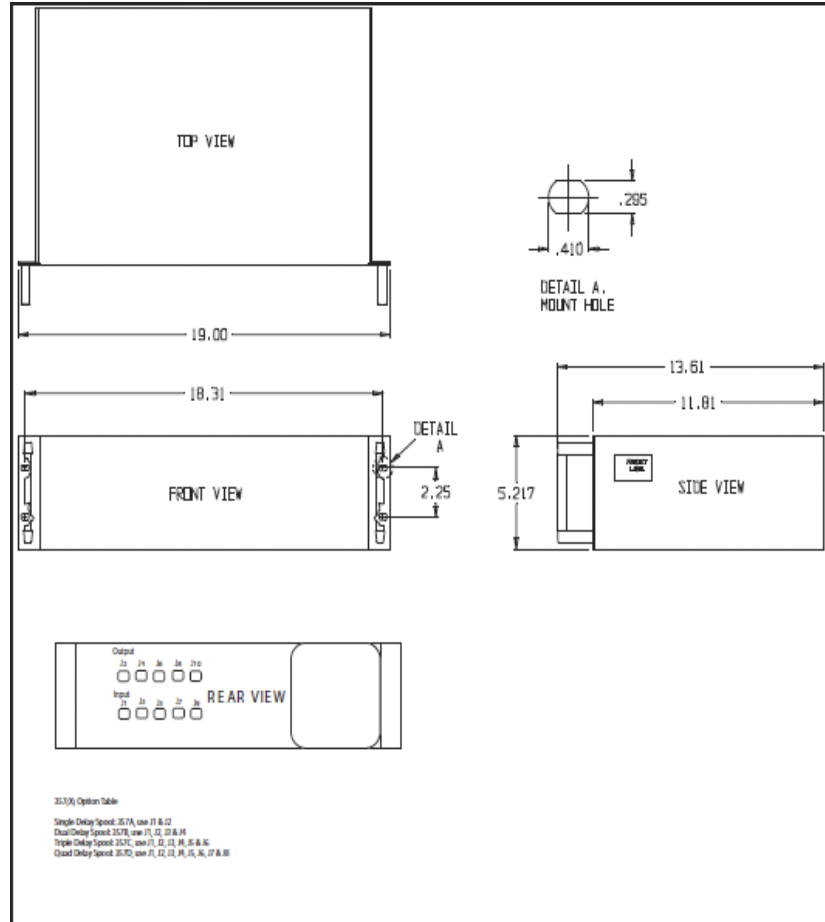

Ordering Information

Description	355A-XXXX	356A-XXXX	356B-XXXX / XXXX	357A-XXXX	357B-XXXX / XXXX	357C - XXXX / XXXX / XXXX	357D - XXXX / XXXX / XXXX / XXXX	357E - XXXX / XXXX / XXXX / XXXX / XXXX
Delay Spool 1 ns - 115 μ s	X	-	-	X	-	-	-	-
Delay Spool 1 ns - 16 μ s	-	X	-	-	-	-	-	-
Dual Delay Spool 1 nS - 8.0 μ s	-	-	X	-	-	-	-	-
Delay Spool >15 μ s - 280 μ s	-	-	-	X	X	X	X	X

Model Number: 35XX-XXXX-XXX

35XX: Package Style 355A, 356A, 356B or 357A/B/C/D/E

-XXXX: Delay time in microseconds (X) 100 (X) 10 (X) 1 (X) 0.1

Example: 85.4 microseconds = 0854

-XXX: Connector Option -020 or -022

