



## Applications

- CATV Systems
- Long Distance RF/Microwave Fiber Optic Communication Links
- Sensing and Control Systems
- High-Performance Supertrunking Links
- High Power Distribution Networks
- Redundant Ring Architectures
- FTTx Networks

## Features

- Full Function Fiber Optic pre-Amplifier
- Low Noise Figure (NF tyo < 3.5 dB)
- Pin: < -4.0 dBm
- Pout(saturated): ≈ +14 to +17 dBm
- Small Signal Gain > 37 dB
- Low Electrical Power Consumption
- Output Isolation > 35 dB
- Polarization Dependant Gain < 0.5 dB
- Polarization Mode Dispersion < 0.5 ps
- Output Return Losses < -40 dB
- Fits in Optiva Enclosures (16, 6, and 2 Slot)
- All Optiva Communication Features
- RoHS Complaint

The Optiva OTS-2OP Series uses Ortel's Micro Erbium Doped Fiber pre-Amplifier ( $\mu$ EDFA) Gain Block Modules which is an ideal building block for system integrators to extend the fiber link for long-haul signal transport. The OTS-2OP Series is designed to meet the most demanding noise performance requirements of fiber optic communications and control systems and performs all the functions required of an optical pre-amplifier for system integration.

The OTS-2OP Series EDFA pre-amplifier modules provide output optical isolation for stable, low-noise operation. The output optical signal power levels are detected for monitoring and control. The very low level input optical signal is pre-amplified, then amplified with active output power control for constant power mode operation.

The OTS-2OP Series also provides local and remote monitors and alarms for all critical operating parameters via SNMP and the Ortel View Graphical Users Interface (GUI). The optical output can be split into multiple ports by optional external splitter.

## System Applications

The OTS-2OP Series modules fit in the Ortel Optiva family of enclosures including the 3 RU 19" rack-mount, **optiva** PLATFORM fan-cooled enclosure (Model OT-CC-16F) supporting up to 16 Optiva modules and the 1 RU 19" rack-mount, fan-cooled enclosure (Model OT-CC-6) supporting up to 6 Optiva modules. In addition, the OTS-2OP Series modules fit the compact tabletop or wall-mountable enclosure Model OT-DTCR-2.

The Ortel Optiva family of platforms consists of a wide range of RF, microwave, video, data and audio signal transport solutions. The integration of the OTS-2OP Series pre-amplifiers and the Optiva family of 1550 nm optical MUX-DEMUX solutions into the platform can extend the fiber links of long-haul signal transport for a wide range of applications.

## Block Diagram

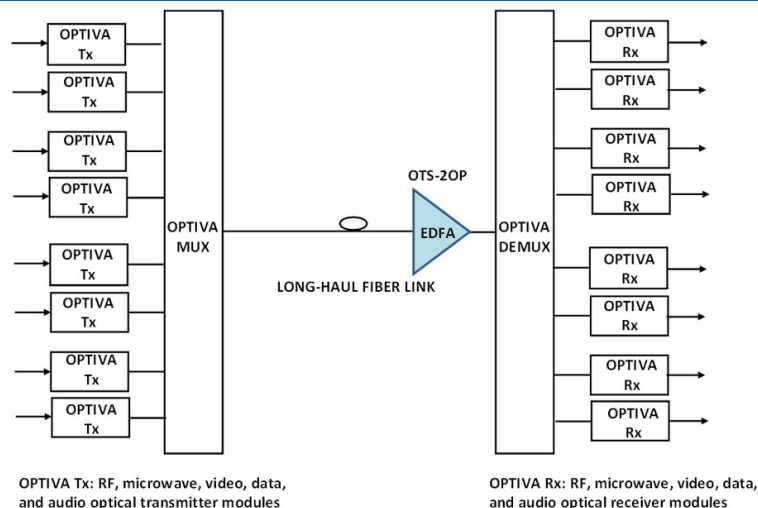

### Optical/Electrical Characteristics

Parameter	Unit	Limit	Model	Model	Comments <sup>(Note 1)</sup>
			5014	5017	
Operating Input Power	Pin (dBm)	Max	≤ -4	≤ -4	
Operating Input Power	Pin (dBm)	Min	-45	-45	
Small Signal Gain	G	Min	37	37	
Saturated Output Power	Pout (dBm)	Nominal	14 +/- .25	17 +/- .25	Notes 2
Noise Figure	NF (dB)	Max	3.5 dB	3.5 dB	Note 3
Output Power Stability	(dB)	Max	+/- 0.3	+/- 0.3	Note 4
Power Consumption (Steady state)	Psys (W)	Max	4		Note 5

NOTES:

- 1) Unless stated otherwise, all specifications apply over the full operating temperature and humidity ranges
- 2) Measured @ 25°C, Pin ≈ -4.0 dBm. λ ≈ 1555 nm
- 3) Measured @ 25°C, Pin ≈ -30 dBm. λ ≈ 1555 nm
- 4) Over polarization and temperature
- 5) Max - power consumption @ -20°C to +70°C case temperatures

### General and Mechanical Specifications

Parameter	Min	Typ	Max	Units	Comments
Operating Wavelength	1530	-	1562	nm	Standard
Operating Case Temperature	0	-	50	°C	Standard
Storage Temperature	-40	-	85	°C	Standard
Operating Humidity	20	-	85	%	Non-Condensing
Optical Connectors	-	SC; FC; E2000	-	-	APC Only
Dimensions		23.03 x 12.85 x 4.04 9.07 x 5.06 x 1.59	-	mm in	All Versions

**Outline Drawing** (dimensions are in inches & mm)

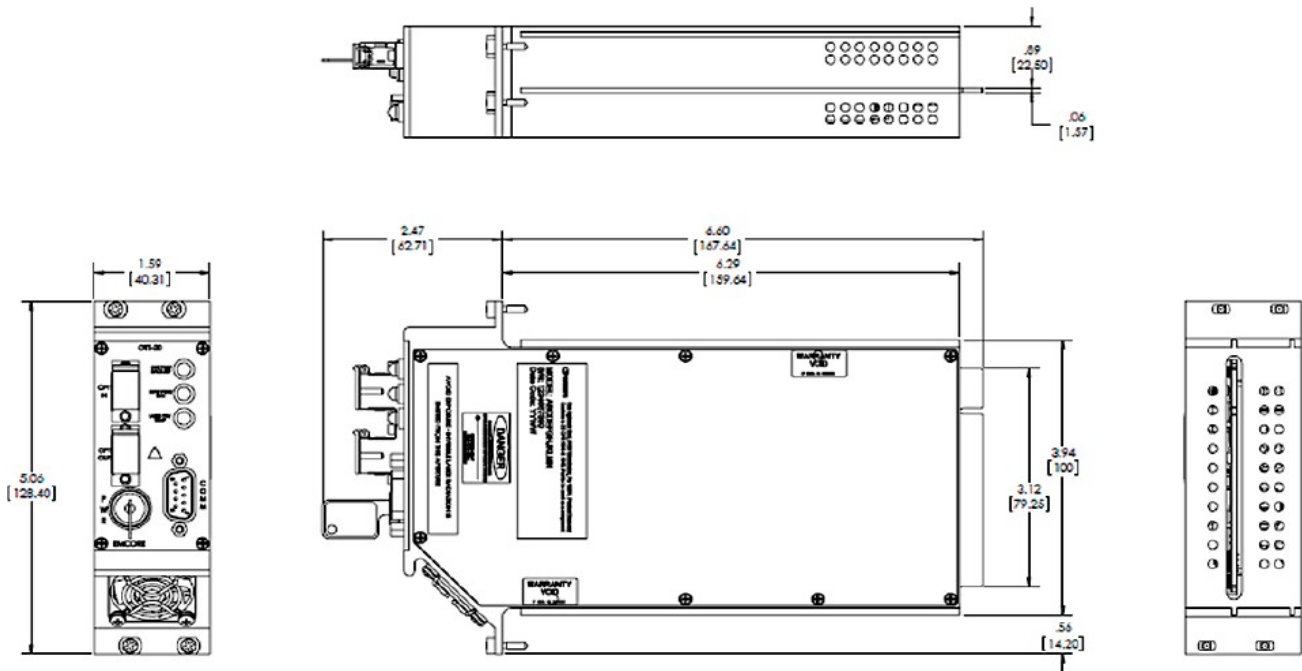

**Compliance and Reliability Information**

FCC: Subpart B. Part 15 Class "A": Unintentional Radiators

EN 55013: Sound and Television Broadcast receivers and associated equipment - Radio disturbance characteristics - limits and methods of measurements - Electric Field Radiation Emissions (2001)

Fit Rate: 90% level of confidence - 325 @ 25°C

## Ordering Information

OTS - 2OP - 

X	X	X	X
---	---	---	---

 - 

Y	Y
---	---

 -

Power Level (XXXX)
5014 - 14 dBm
5017 - 17 dBm

Connection Option (YY)
SA - SC/APC
FA - FC/APC
EA - E2000/APC

Example:

OTS-2OP-5014-SA: 14 dBm gain block with SC/APC optical connectors.

Note: Please contact your Sales Representative for other specific requirements.

## Laser Safety

This product meets the applicable requirements of 21 CFR 1010 & 1040 and is classified as a Class 1 laser product based on the maximum optical output power shown below. During use as intended, the laser energy is fully contained within the fiber network such that there is no accessible laser radiation and would meet the requirements for a Class 1 laser product.

Wavelength = 1530 ~ 1562 nm (dependent on input source)

Maximum Output Power = 0.05 W (single output, 17 dBm model)

