

SITU3018/3118 .01-18 GHz Externally-Modulated Unamplified Transmitter

DATASHEET | JANUARY 2024

MICROWAVE



Applications

- Microwave Antenna Signal Distribution
- Broadband Delay Line and Signal Processing Systems
- Frequency Distribution Systems
- Radar System Calibration
- Phased Array Antenna Systems
- Interferometric Antenna Arrays

Features

- 10 MHz – 18 GHz Frequency Range
- 7 dBm or 10 dBm Optical Output
- High-Dynamic-Range
- Fully Integrated Unit
- Bias Control Circuits for Laser and Modulator

The Ortel SITU3018/3118 (Small Integrated Transmitter Unit) is a high-performance externally-modulated transmitter for applications from 10 MHz to 18 GHz. The SITU family is a fully-integrated unit that contains both the optics and the control electronics. Only DC input voltages and the RF signal are required for operation.

The broad bandwidth of the unit makes it ideal to construct transparent links for microwave antenna signal distribution, Electronic Warfare (EW) systems and satcom systems. Other applications include delay lines, signal processing, radar system calibration, phased array antennas and other systems where it is necessary to transport RF and microwave signals over long distances without signal degradation.

The system operates at a nominal optical wavelength of 1550 nm. Wavelength selected lasers on the ITU grid are also available for WDM applications.

Performance Highlights

| Parameter | Min | Typical | Max | Units |
|----------------------|-----|---------|-----|-------|
| Frequency Range | .01 | - | 18 | GHz |
| RF Input Power | 0 | - | +25 | dBm |
| Wavelength | - | 1550 | - | nm |
| Optical Output Power | | | | |
| SITU 3018 | 7 | 8 | 9 | dBm |
| SITU 3118 | 10 | 11 | 12 | dBm |
| Temperature Range | -40 | - | 70 | °C |

Block Diagram

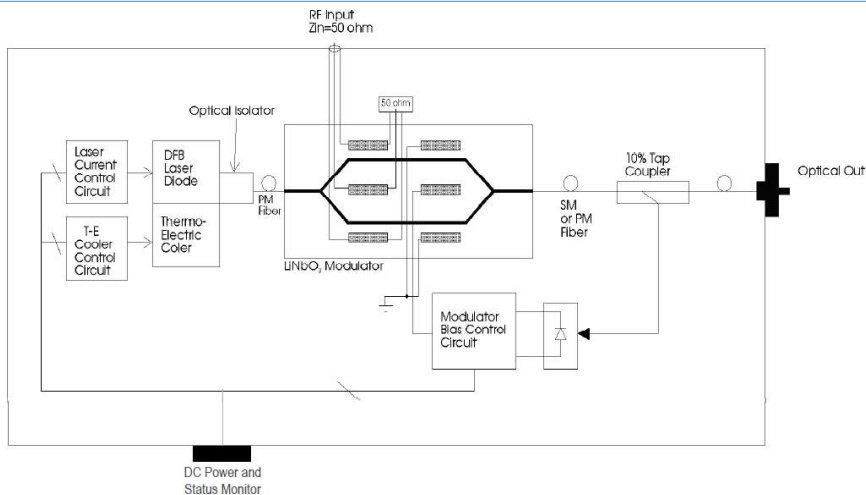

SITU3018/3118 .01-18 GHz Externally-Modulated Unamplified Transmitter

Absolute Maximum Ratings

Stresses in excess of the absolute maximum ratings can cause permanent damage to the device. These are absolute stress ratings only. Functional operation of the device is not implied at these or any other conditions in excess of those given in the operational sections of the data sheet. Exposure to absolute maximum ratings for extended periods can adversely affect device reliability.

| Parameter | Symbol | Min | Max | Units |
|---|-----------|-----|-----|-------|
| Operating Temperature (within specifications) | T_{OP} | 0 | 50 | °C |
| Operating Temperature (with degraded performance) | T_{OP} | -40 | 70 | °C |
| Storage Temperature | T_{STG} | -40 | 70 | °C |
| RF Input (damage level threshold) | S_{IN} | NA | 25 | dBm |
| Receiver Optical Input Power (damage level threshold) | SIRU3000 | NA | +13 | dBm |

Optical Specifications

| Parameter | Symbol | Condition | Min | Typical | Max | Unit |
|------------------------------|-----------|--------------------------------------|--------|---------|----------|------------|
| Wavelength | λ | - | 1530 | 1550 | 1562 | nm |
| Optical Output Power | P_L | SITU3018 Version SITU3118 Version | 7 9 | - - | 10 12 | dBm dBm |
| Transmitter Source Laser RIN | - | - | - | -165 | -163 | db-Hz |
| Connector Return Loss | - | - | 60 | - | - | dB |
| Optical Connector Type | - | FC/APC, AVIM | - | - | - | - |

Note: In order to prevent reflection-induced distortion degradation, the laser should be connected to an optical cable having a return loss of at least 55 dB for discrete reflections and 30 dB for distributed reflections.

Transmitter RF Specifications

| Parameter | Symbol | Condition | Min | Typical | Max | Unit |
|--------------------------------------|--------|----------------------------------|-------------------|-------------------|-------------|-------------------|
| Operational Bandwidth | | SITU Version | 0.01 | - | 18 | GHz |
| RF Input Impedance | | - | - | 50 | - | Ω |
| RF Return Loss | | - | 9 | 18 | - | dB |
| Transmitter Gain (@ +7 dBm Optical) | TG | @ 10 GHz @ 18 GHz | 22 22 | 18 18 | - - | dB dB |
| Transmitter Gain (@ +10 dBm Optical) | TG | @10 GHz @ 18 GHz | 16 16 | 12 12 | - - | dB dB |
| 2nd Harmonic Suppression | IP2 | RF Input 0 dBm | 60 | 70 | - | dBc |
| 1 dB Compression Point | | @ 10 GHz @ 13 GHz @ 18 GHz | +13 +13 +13 | +15 +15 +17 | - - - | dBm dBm dBm |
| RF Connector | | SITU3x18 Version SMA | - | 50 | - | ohm |

SITU3018/3118 .01-18 GHz Externally-Modulated Unamplified Transmitter

Broadband Link Performance

SITU3018 transmitter @ quadrature bias with 0 dBm RF input and SIRU3018 receiver with +7 dBm and +10 dBm optical input

| Parameter | Symbol | Condition | Min | Typical | Max | Unit |
|---|--------|----------------------|------|---------|-----|---------------------|
| RF Bandwidth | - | - | 0.05 | - | 18 | GHz |
| Link Gain (+7 dBm Rx Optical Input) | | @ 10 GHz | -34 | -30 | - | dB |
| | | @ 18 GHz | -34 | -30 | - | dB |
| Link Gain (+10 dBm Rx Optical Input) | | @ 10 GHz | -28 | -24 | - | dB |
| | | @ 18 GHz | -28 | -24 | - | dB |
| Noise Figure (+7 dBm RX Optical Input) | | @ 10 GHz | 40 | 39 | - | dB |
| | | @ 18 GHz | 40 | 39 | - | dB |
| Noise Figure (+10 dBm Rx Optical Input) | NF | @ 10 GHz | 37 | 36 | - | dB |
| | | @ 18 GHz | 37 | 36 | - | dB |
| Input IP3 | IIP3 | @ 10 GHz | - | +23 | - | dBm |
| | | @ 18 GHz | - | +28 | - | dBm |
| Spurious Free Dynamic Range | SFDR | @ 7 dBm Rx Optical | 105 | 107 | - | dB-Hz ²³ |
| | | @ +10 dBm Rx Optical | 108 | 110 | - | dB-Hz ²³ |
| Gain Variation | | 1 GHz to 18 GHz | - | 5 | 10 | dB |

Package Outline

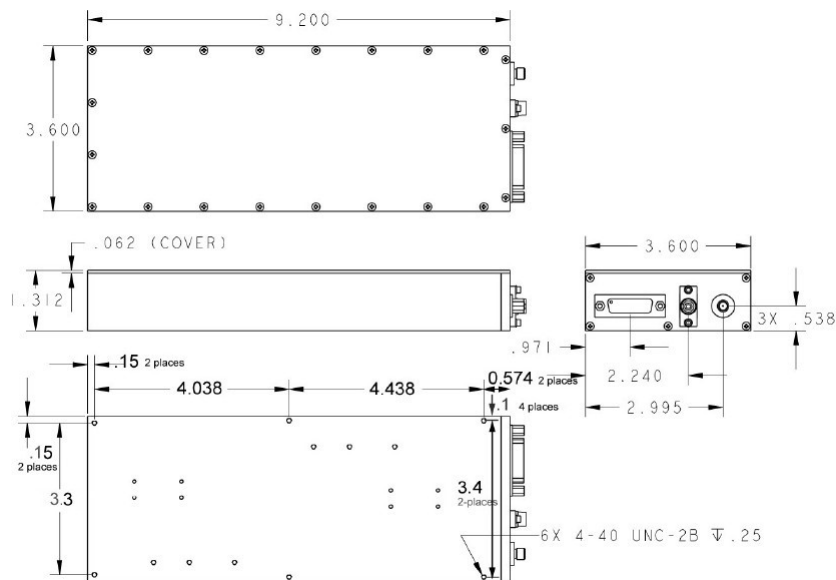

SITU3018/3118 .01-18 GHz Externally-Modulated Unamplified Transmitter

SITU3018/3118 Typical S21 Frequency Response

SITU3018 transmitter with 0 dBm RF input and SIRU3018 receiver with 0 dBm optical output.

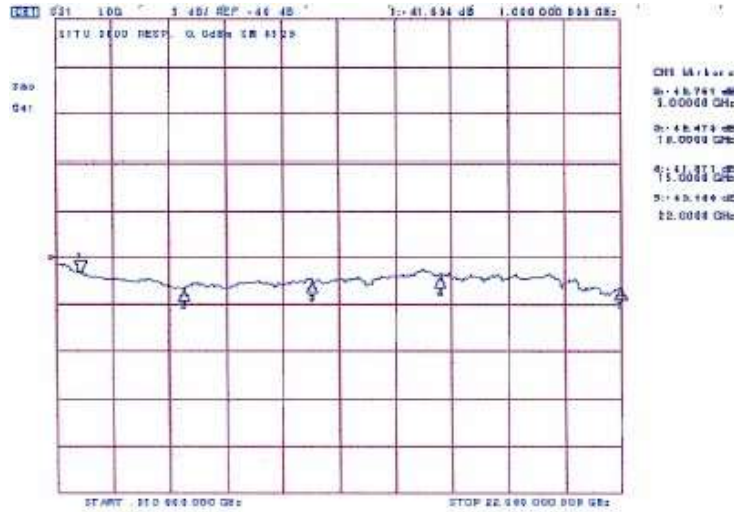

D-Connector Pin Out

| Pin | Function | Comments |
|-----|--------------------------|-----------------|
| 1 | +15 VDC | |
| 2 | -15 VDC | |
| 3 | +5 VDC | |
| 4 | -5 VDC | |
| 5 | Laser Current Monitor | 1 V/A |
| 6 | Optical Power Monitor | 0.25 V/mW |
| 7 | Reserved for Factory Use | |
| 8 | Reserved for Factory Use | |
| 9 | Tx Power Control | 0 V off; 5 V on |
| 10 | NC | |
| 11 | NC | |
| 12 | GND | |
| 13 | GND | |
| 14 | GND | |
| 15 | Reserved for Factory Use | |

Physical Parameters

| Parameter | Condition | Min | Typical | Max | Unit |
|-------------------------------|-------------------------|-----|---------|-----|------|
| Configuration | Self Contained Housing | - | - | - | - |
| Dimensions | 1.3 H x 3.6 W x 9.2 D | - | - | - | in |
| | 33 H x 91.4 W x 233.7 D | - | - | - | mm |
| Operating/Storage Temperature | | -40 | - | +70 | °C |
| Weight | - | - | 29 | - | oz |
| | | | 822.14 | - | g |

DC Power Consumption

| Input Voltage | Max Current |
|---------------|-------------|
| +5 | 2 A |
| +15 | 0.1 A |
| -5 | 0.4 A |
| -15 | 0.1 A |

SITU3018/3118 .01-18 GHz Externally-Modulated Unamplified Transmitter

Ordering Information

Transmitter Modules:

| Product Name | Description |
|------------------|--|
| SITU3018-00-FA | 0.01 - 18 GHz Externally-Modulated Fiber Optic Transmitter Module, 7 dBm Optical Output, FC/APC |
| SITU3118-00-FA | 0.01 - 18 GHz Externally-Modulated Fiber Optic Transmitter Module, 10 dBm Optical Output, FC/APC |
| SITU3018-00-AVIM | 0.01 - 18 GHz Externally-Modulated Fiber Optic Transmitter Module, 7 dBm Optical Output, AVIM |
| SITU3118-00-AVIM | 0.01 - 18 GHz Externally-Modulated Fiber Optic Transmitter Module, 10 dBm Optical Output, AVIM |

Laser Safety

This product meets the appropriate standard in Title 21 of the Code of Federal Regulations (CFR). FDA/CDRH Class 1M laser product. This device has been classified with the FDA/CDRH under accession number 0220191. All Versions of this laser are Class 1M laser product, tested according to IEC 60825-1:2007 / EN 60825-1:2007. An additional warning for Class 1M laser products. For diverging beams, this warning shall state that viewing the laser output with certain optical instruments (for example: eye loupes, magnifiers, and microscopes) within a distance of 100 mm may pose an eye hazard. For collimated beams, this warning shall state that viewing the laser output with certain instruments designed for use at a distance (for example: telescopes and binoculars) may pose an eye hazard.

Wavelength = 1.3/1.5 μ m.

Maximum power = 30 mW.

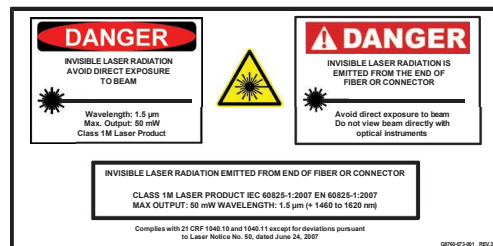

*Caution - Use of controls or adjustments or performance of procedures other than those specified herein may result in hazardous radiation exposure.

*IEC is a registered trademark of the International Electrotechnical Commission.

**MADE IN
USA**