

## Applications

- DWDM
- Sensing
- Free Space Optics

## Features

- 40, 50, & 63 mW Optical Output Power
- OC-48 Pinout Compatible
- Telcordia Technologies® GR-468 Compliant
- PM Fiber
- -20 °C to +65 °C Operating Temperature Range
- Monitor Photodiode
- RoHS

Ortel's 1786 laser module is characterized for use as a CW optical source in sensing and DWDM networks. It features narrow linewidth and high coherence. The 1786 is DC-coupled with a built-in TEC, thermistor, and monitor photodiode. The device is mounted in a 14-pin, OC-48 pinout compatible butterfly package with the optical isolator mounted on the TEC. The 1786 incorporates a high efficiency coupling scheme to deliver 40 mW, 50 mW and 63 mW of CW optical power.

## Performance Highlights

Parameter	Min	Typ	Max	Units
Operating Case Temperature	-20	25	+65	°C
Wavelength	1550			nm
Optical Output Power	40 50 63	- - -	- - -	mW
Threshold Current	-	-	40	mA
Operating Current	-	-	650	mA
RIN <sup>(1)</sup>	-	-	-155	dB/Hz
Laser linewidth			300	kHz
SMSR	30	-	-	dB
Polarization Extinction Ratio (PMF pigtail)	17	-	-	dB
Optical Return Loss	40	-	-	dB

(1) RIN measured at COB level with 65 km fiber

## Absolute Maximum Ratings

Stresses in excess of the absolute maximum ratings can cause permanent damage to the device. These are absolute stress ratings only. Functional operation of the device is not implied at these or any other conditions in excess of those given in the operational sections of the data sheet. Exposure to absolute maximum ratings for extended periods can adversely affect device reliability.

Parameter	Symbol	Condition	Min	Max	Units
Operating Case Temperature	$T_{OP}$	continuous	-20	+65	°C
Storage Temperature	$T_{STG}$	continuous	-40	+85	°C
Laser Forward dc Current	-	continuous	-	750	mA
Photodiode Reverse Voltage	$V_{R,MPD}$	continuous	-	10	V
Laser Reverse Voltage	-	continuous	-	2	V
TEC current	$I_{TEC}$	continuous	-	1.7	A
ESD	-	HBM: R = 1500 $\Omega$ , C = 100 pF	-500	500	V

## Electrical/Optical Characteristics

Parameter	Symbol	Condition	Min	Typ	Max	Unit
Operating Case Temperature	$T_{OP}$	-	-20	25	65	°C
Optical Output Power	$P_O$	40 mW version, $T = T_{set}$ , $I_F = I_{OP}$ 50 mW version, $T = T_{set}$ , $I_F = I_{OP}$ 63 mW version, $T = T_{set}$ , $I_F = I_{OP}$	40 50 63	- - -	- - -	mW
Threshold Current	$I_{TH}$	BOL	-	-	40	mA
Operating Current	$I_{OP}$	BOL, $T = T_{OP}$ 63 mW Option 50 mW Option 40 mW Option	- - -	- - -	500 400 350	mA
Operating Laser Temperature	-	-	18	-	35	°C
Laser Bias Forward Voltage	$V_{OP}$	BOL, $I_F = I_{OP}$	-	-	2.7	V
Wavelength	$\lambda_{OP}$	$T = T_{set}$ , $I_F = I_{OP}$	1550			nm
Laser Linewidth <sup>(1)</sup>	$\Delta\nu$	$T = T_{set}$ , $I_F = I_{OP}$ , FWHM	-	-	300	kHz
Optical Return Loss	ORL	-	40	-	-	dB
Sidemode Suppression Ratio	SMSR	-	30	-	-	dB
Polarization Extinction Ratio	PER	$I_F = I_{OP}$	17	-	-	dB
Wavelength Drift Over $T_C$ Range	$\Delta\nu_{TOP}$	$T = T_{OP}$	-	-	40	pm
Relative Intensity Noise <sup>(2)</sup>	RIN	-	-	-	-155	dB/Hz
Monitor PD Current	$I_{MPD}$	$I_F = I_{OP}$ , $V_{MPD} = -5$ V	100	-	2500	$\mu$ A
Monitor PD Dark Current	$I_D$	$I_{OP} = 0$ mA, $V_{MPD} = -5$ V	-	-	0.2	$\mu$ A
Thermistor Resistance	$R_{TH}$	$T_{OP} = 25$ °C	9.5	10.0	10.5	K $\Omega$
Thermistor Temp. Coefficients	$TC_{TH}$	$T_{OP} = 25$ °C	-	-4.4	-	%/°C
TEC Current	$I_{TEC}$	-20°C < $T_C$ < +65°C	-1.0	-	+1.5	A
TEC Voltage	$V_{TEC}$	-20°C < $T_C$ < +65°C	-2.0	-	+3.0	V

(1) Measured through laser frequency noise. The linewidth is calculated as  $\pi \cdot \text{Frequency noise at 100 kHz}$ .

(2) RIN measured at COB level with 65 km fiber

## Outline Drawing

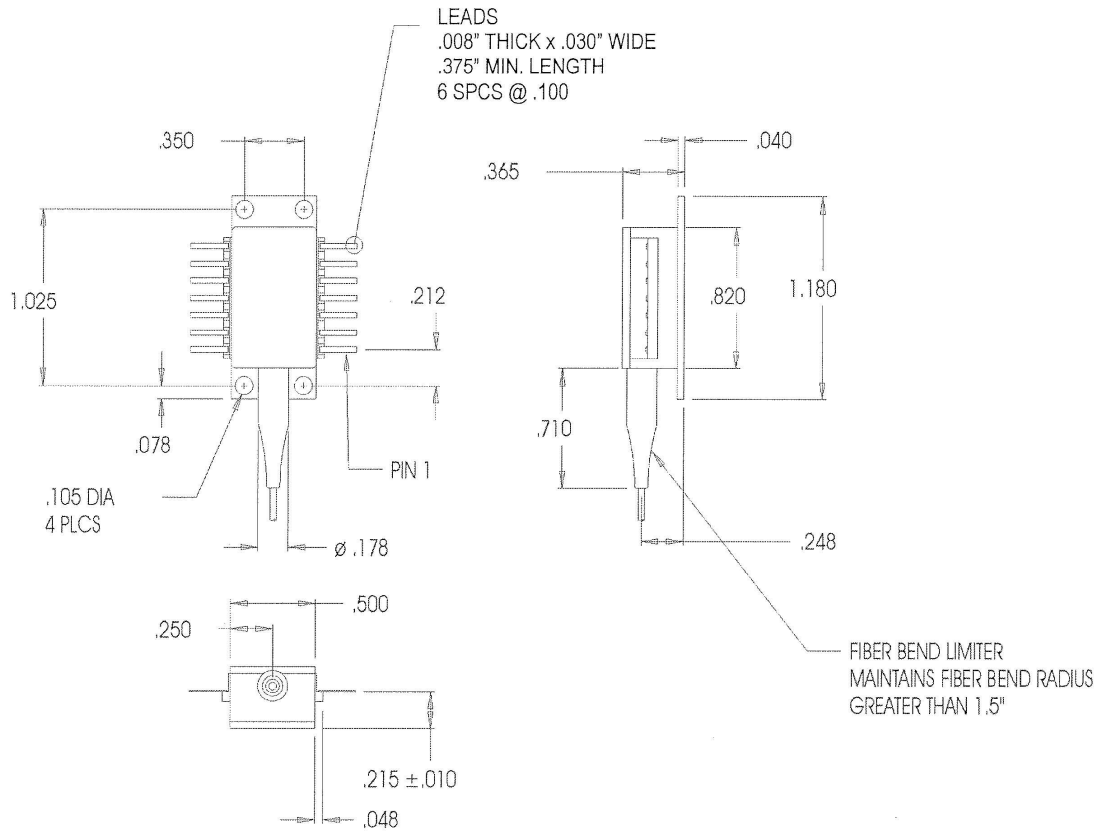

## Pin Assignments

Pin	Description
1	Thermistor
2	Thermistor
3	Dc Laser Bias (-)
4	MPD Anode (-)
5	MPD Cathode (+)
6	Thermal Electric Cooler (+)
7	Thermal Electric Cooler (-)
8	Case Ground
9	Case Ground
10	NC
11	Laser Common (+),
12	Laser Modulation (-)
13	NC, or Ground
14	NC

## Laser Safety

This product complies with 21 CFR 1040.10 and 1040.11 except for deviations pursuant to Laser Notice No. 50, dated June 24, 2007.

All Versions of this laser are Class 1M laser product, tested according to IEC 60825-1:2014/EN 60825-1:2014

Single-mode fiber pigtail with FC/APC connectors (standard).

Wavelength = 1550 nm.

Maximum power = 63 mW.

Because of size constraints, laser safety labeling (including an FDA class 1M label) is not affixed to the module, but attached to the outside of the shipping carton.

Product is not shipped with power supply.

**Caution: Use of controls, adjustments and procedures other than those specified herein may result in hazardous laser radiation exposure.**



## Ordering Code Definitions

1786x – xx – xxx – yy – FC - PM

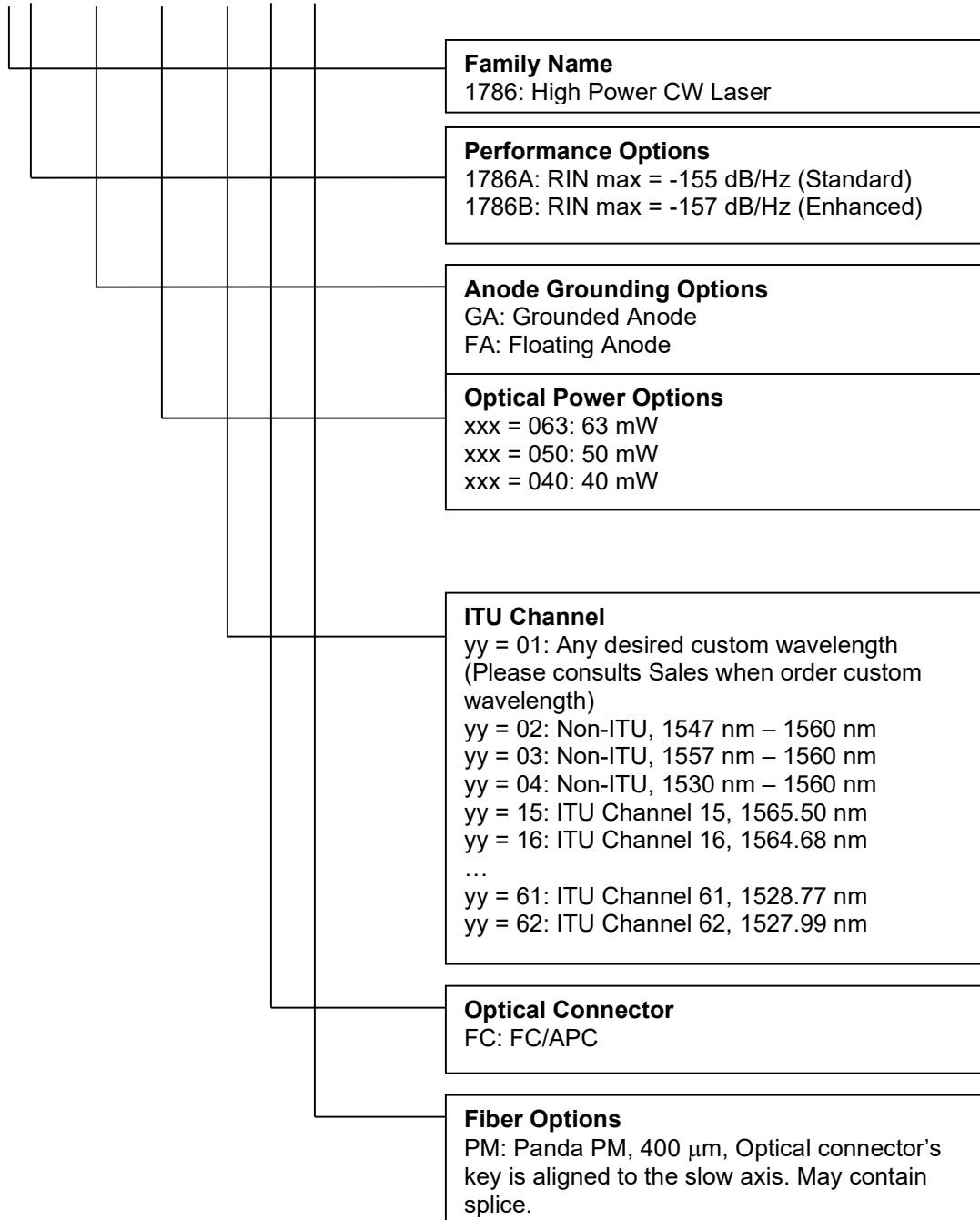

## Example

**1786B-GA-040-18-FC-PM:** CW Laser, Enhanced RIN, Grounded Anode, 40mW, Channel 18, FC/APC, PM fiber