

MAFA 5000 Series Erbium Doped Fiber Amplifier



DATASHEET | JANUARY 2024

CATV & MICROWAVE



Applications

- CATV Systems
- Long Distance RF/Microwave Fiber Optic Communication Links
- Sensing and Control Systems
- High-Performance Supertrunking Links
- Redundant Ring Architectures
- FTTx Networks

Features

- Full Function Fiber Optic Amplifier Ready for Integration
- Wavelength Range: 1530 nm to 1562 nm
- Low Noise Figure (Typ < 5.0 dB)
- Pin: -10dBm to +12 dBm
- Pout: +14 dBm to +24.5 dBm
- RS-232 Monitor and Control Interface
- Low Electrical Power Consumption
- Input / Output Isolation > 35 dB / 35 dB
- Polarization Dependent Gain (PDG) < 0.5 dB
- Polarization Mode Dispersion (PMD) < 0.5 ps/√km
- Output Residual Pump Power < -30dB (in reference to the output signal power)
- Input & Output Return Losses < -40 dB
- Polarization Dependent Loss < 0.3 dB

The Ortel MAFA 5000 Series Micro Erbium Doped Fiber Amplifier (μ EDFA) gain block module is an ideal building block for OEM systems integration where there is a requirement to amplify a 1550 nm signal for a broad range of applications including CATV systems, RF/microwave fiber optic links, sensing and control systems, and more. The family of MAFA 5000 EDFA gain blocks is designed to meet the most demanding noise performance requirements of fiber optic communications & control systems and perform all the functions required of an optical amplifier for system integration.

MAFA 5000 series EDFA gain blocks provide input and output optical isolation for stable, low noise operation. The input and output optical signals are detected for monitoring and control. The input optical signal is amplified with active gain control for a constant output power level or with active output power control for constant gain mode operation.

The MAFA 5000 series EDFA gain blocks also provide monitors and associated alarms for all critical operating parameters. The optical output of the MAFA 5000 series EDFA gain blocks can be split into multiple ports (2, 3 or 4) by an optional internal splitter.

The compact mechanical footprint of the MAFA 5000 allows use of this unit in constrained space environments and high-density applications.

MAFA 5000 Series Erbium Doped Fiber Amplifier



Optical/Electrical Characteristics Note 1

Property	Unit	Limit	Models						Comments
			14	17	20	22	23	24	
Operating Input Power	Pin (dBm)	Max	12	12	12	12	12	12	Typical (may vary for some models)
Operating Input Power	Pin (dBm)	Min	-10	-10	-10	-10	-10	-10	Typical (may vary for some models)
Total Output Power	Po (dBm)	Nominal	14 +/- .25	17 +/- .25	20 +/- .25	22 +/- .25	23 +/- .25	24.5 +/- .25	Before Splitter (if installed)
Noise Figure	NF (dB)	Typ	≤ 5.0 dB	≤ 5.0 dB	≤ 5.0 dB	≤ 5.0 dB	≤ 5.0 dB	≤ 5.0 dB	Note 2
Dynamic Gain Flatness	ΔGd (dB)	Max	+/-2.0	+/-2.0	+/-2.5	+/-2.5	+/-2.5	+/- 8.0	Note 3
Output Power Stability	(dB)	Max	+/- 0.2	+/- 0.2	+/- 0.2	+/- 0.2	+/- 0.2	+/- 0.2	Note 4
Power Consumption (Steady state)	Psys(W)	Max	3	5.5	8	9	11	13	Note 5

Notes:

- 1) Unless stated otherwise, all specifications apply over the full operating temperature and humidity ranges
- 2) Measured @ 25°C, Pin = 0 dBm, λ = 1555 nm
- 3) Measured by combining a small-probe signal (Pin – 20 dB) with the signal (Pin) that sets the EDFA to defined saturation level of Pout. 0 dBm ≤ Pin ≤ 6 dBm (*"Fiber Optic Test and Measurement" HP, Dennis Derickson, Editor, ISBN 0-13-534330-5, 1998, page 54*)
- 4) Over polarization and temperature
- 5) Max - power consumption @ -20°C or +70°C case temperatures

Field Code Changed

General and Mechanical Specifications

Property	Requirement	Comments
Operating Wavelength	1530nm ~ 1562nm	Standard
Operating Case Temperature	0°C to 65°C	Standard*
Storage Temperature	-40°C to 85°C	Standard
Operating Humidity	up to 95%	Non-condensing
Voltage Supply Range	+4.75 to 5.25 VDC	All versions
Optical Connectors	SC, FC, E2000, LC	User Specified
Dimensions (mm)	70 x 90 x 15	All versions
Weight (kg)	0.12	All versions

* Extended case temperature range of -20°C to +70°C is also possible

Information contained herein is deemed reliable and accurate as of the issue date. ORTEL reserves the right to change the design or specification at any time without notice. ORTEL is a registered trademark of ORTEL Corporation in the U.S. and other countries.

MAFA 5000 Series Erbium Doped Fiber Amplifier



DATASHEET | JANUARY 2024

CATV & MICROWAVE

Outline Drawing (dimensions in mm)

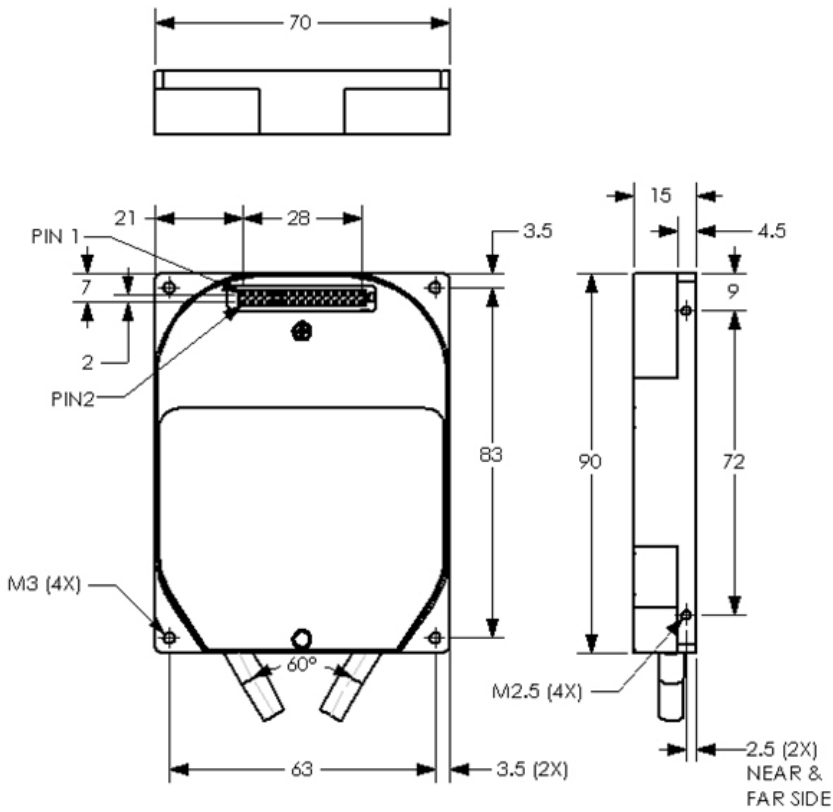

Compliance and Reliability Information

Class 3B Laser Safety
221,000 hours MTBF at 50°C per Telcordia SR-332, Issue 2

MAFA 5000 Series Erbium Doped Fiber Amplifier



Electrical Connector Pinout

PIN #	Designation	PIN #	Designation
1	5VDC	16	NC
2	+5VDC	17	Pump_Temp_Alarm (TTL active high)
3	+5VDC	18	Pump_Bias_Alarm (TTL active high)
4	+5VDC	19	Loss_Input_Power (TTL active high)
5	GND	20	Loss_Output_Power (TTL active high)
6	GND	21	GND
7	RS232_Rx	22	GND
8	RS232_Tx	23	Input Power Mon
9	GND	24	Output Power Mon
10	GND	25	GND
11	NC	26	GND
12	EDFA_Reset (TTL active high)	27	RxD (Factory Use)
13	EDFA_Disable (TTL active high)	28	TxD (Factory Use)
14	Pout_Mute (TTL active high)	29	+5VDC
15	EDFA_Temp_Alarm (TTL active high)	30	+5VDC

* - SAMTEC, TMM-115-01-L-D

Ordering Information

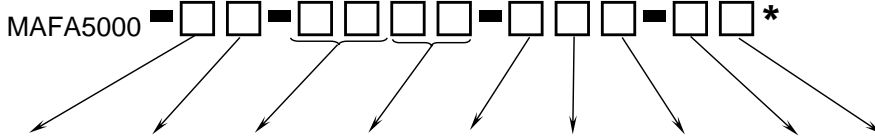

Logo & Customer Specifics	Temperature Option	Output Power Per Port, dBm	Number of Output Ports	Input Connector Type	Output Connectors Type	Required Power Supply	Future Use	Future Use
0 = Ortel Logo	S = Standard	08 = 8	01 = 1 port	1 = SC/APC	1 = SC / APC	1 = +5VDC	0 = NA	0 = NA
		11 = 11		2 = FC/APC	2 = FC / APC			
	E = Extended	14 = 14	02 = 2 ports	3 = E2000 / APC	3 = E2000 / APC			
		17 = 17		4 = LC / APC	4 = LC / APC			
		20 = 20	03 = 3 ports					
		21 = 21						
		22 = 22	04 = 4 ports					
		23 = 23						
		24 = 24						

* In any unit the combination of "Output Power Per Port" x "Number of Output Ports" cannot ever be higher than the maximum Total Output Power of 24.5 dBm

Example: MAFA5000-0S-1401-111-00: MAFA5000 gain block, with EMCORE logo, standard temperature range, 14 dBm per port, 1 output port, SC/APC connector on input, SC/APC connector on output, +5VDC power supply required

MAFA 5000 Series Erbium Doped Fiber Amplifier



Laser Safety Information

This component product is classified as a Class 3B laser product based on the maximum optical output power defined below

Wavelength = 1530 nm ~ 1562 nm (dependent on input source)

Maximum Output Power < 0.3 W (single output, 24.5 dBm model)

The MAFA 5000 has been assigned accession number 16R0036-000

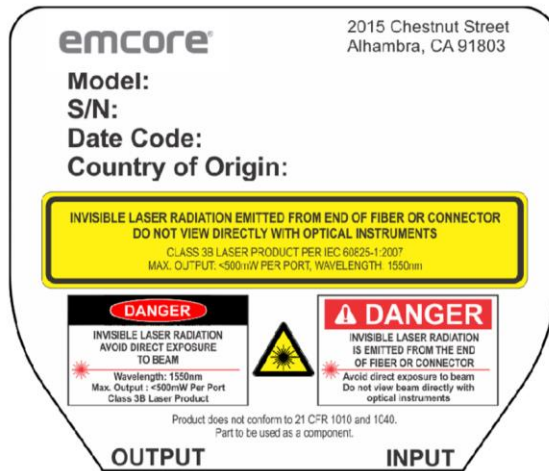

RoHS Compliance

All homogenous materials contained in the product contain less than the maximum concentration levels for lead, mercury, cadmium, hexavalent chromium, polybrominated biphenyls (PBB) and polybrominated biphenyl ethers (PBDE), Bis(2-ethylhexyl) phthalate (DEHP), Dibutyl phthalate (DBP), Butyl benzyl phthalate (BBP), Diisobutyl phthalate (DiBP) permitted under the European Union Directive (EU) 2015/863 (the "RoHS 3 Directive").

Information contained herein is deemed reliable and accurate as of the issue date. ORTEL reserves the right to change the design or specification at any time without notice. ORTEL is a registered trademark of ORTEL Corporation in the U.S. and other countries.